



Incremental Encoders

Basics

Use an incremental encoder when retention of absolute position upon power loss is not required. Examples include velocity control and simple point-to-point applications.

Basic Operation of Optical Rotary Incremental Encoders

Optical rotary incremental encoders consist of five main components:

- LED light source
- Rotating code disk
- Stationary mask
- Photodetector(s)
- Amplifying/squaring electronics

As the code disk rotates in front of the stationary mask, it shutters light from the LED. The light that passes through the mask is received by the photodetector, which produces pulses in the form of a quasi-sine wave. The encoder electronics convert the sine wave into a square signal, ready for transmission to a counter.

Conventional Code Disks

Conventional incremental code disks contain a fixed number of equally spaced opaque lines that produce a corresponding number of pulses per revolution. Each line count requires a unique code disk. The position and spacing of the lines on the disk requires a high degree of precision. Physical limitations determine the maximum number of lines that can be created on a code disk of a given size.

Tachometer Encoders

A single channel (e.g. A) incremental encoder, or tachometer, is used in systems that operate in only one

direction and require simple velocity information. Velocity can be determined from the time interval between pulses, or by the number of pulses within a given time period.

Quadrature Encoders

Quadrature encoders have dual channels, A and B, which are electrically phased 90° apart. Thus, direction of rotation can be determined by monitoring the phase relationship between the two channels.

In addition, with a dual-channel encoder, a four times multiplication of resolution can be achieved by externally counting the rising and falling edges of each channel (A and B). For example, an encoder that produces 2,500 pulses per revolution can generate 10,000 counts after quadrature.

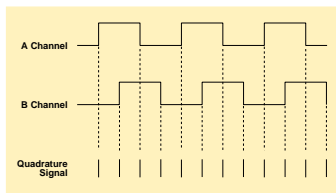

Differential Outputs

Correct position information can depend on eliminating false signals caused by external electrical noise. An encoder with complemented outputs, in combination with a control that uses differential operational-amplifiers, can minimize noise problems. When channel A goes high, its complement channel A/ goes low. Electrical noise will affect both channels in the same way, and can thus be ignored by the differential op-amps.

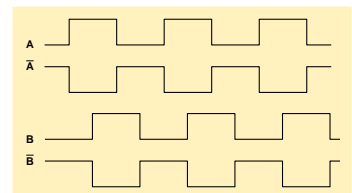

Marker Pulse

The zero, or marker pulse is a rectangular pulse that is transmitted once per revolution. It is used as a reference to a defined mechanical position, mainly during commissioning or start-up after power loss.



For detailed, up-to-date specifications, CAD drawings, application examples and reference information, go to:

www.stegmann.com

For documentation on specific products, use our fax back system in the web site or call our 24-hour fax back system

916-431-6545

and follow the recorded instructions. See the selection guides in this brochure for specific document numbers.

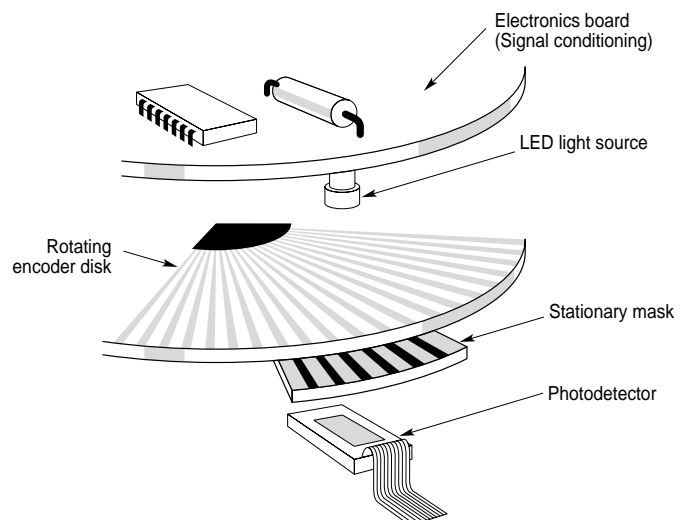

The basic structure of an incremental encoder with conventional code disk.

Bandwidth Considerations

Encoder resolution and shaft speed determine the frequency of the output signals. Careful consideration of the application requirements and the encoder capabilities is required.

CoreTech® Technology

Stegmann's CoreTech® concept uses a minimum number of very sophisticated components to achieve maximum variety: A proprietary hybrid OPTO-ASIC, designed by Stegmann, and a small, unique disk with a barcode track.

Unique Code Disk Design

The very small CoreTech® code disk condenses absolute position information into one non-repeating circular barcode pattern. A second track with 1024 analog sin/cosine signals is used to enhance resolution and



accuracy. The resulting absolute position information is used to define the rising and falling edges of channels A and B, which in turn determines the number of pulses per revolution. Any incremental line count from 1 to 8,192 can be configured via internal software based on the single unique code disk design.

A Photodetector Array

The CoreTech® pickup system is also very different from conventional encoder systems. The sensitive area of the OPTO-ASIC consists of a sophisticated sensor array, where individual sensors are selectively accessible. The sensor array reads complete serial data strings from the barcode track. At the same time a separate section of the array reads the very precise sine/cosine information, which is transformed into a high-resolution ARCTAN value within the



hardwired ASIC. After synchronization of the two signals, the desired resolution and accuracy for the position data is obtained. Absolutely no angular movement is required to read the position information. Due to the high integration level of the custom ASIC, the complete operation is processed in real-time. Customer-specific resolutions are factory-selected for the CoreTech® module via firmware.

Electronic Zero Pulse

With CoreTech®, the zero pulse is electronically assigned by the user to the current mechanical position by activating a setline. No mechanical detachment or rotation of the encoder is necessary.

Enhanced Bandwidth Capability

CoreTech® encoders, with integrated OPTO-ASIC technology, have frequency response capability as high as 820 kHz. ■

