

# Motor Feedback Systems



## SinCos® Servo Motor Feedback

Stegmann's SinCos® family of servo motor feedback devices combines commutation, speed regulation, and position information in a single device.

Initial absolute position values up to 15-bit, combined with incremental resolution up to 4 million counts per turn, provide position accuracy down to  $\pm 5$  arc seconds — all in package sizes as small as 36 mm diameter!

This is accomplished using a small number of very sophisticated components: A proprietary hybrid OPTO-ASIC, designed by Stegmann, and a small, unique disk with barcode and incremental tracks.

### Unique Code Disk Design

The very small SinCos® code disk condenses absolute position information into one non-repeating circular barcode pattern. A second track with analog sin/cosine signals is used to enhance resolution and accuracy. Absolute position up

to 15-bit is available upon motor start-up, and any time it is requested by the motor drive - such as for synchronization.



### A Photodetector Array

The SinCos® pickup system is also very different from conventional encoder systems. The sensitive area of the OPTO-ASIC consists of a sophisticated sensor array, where individual sensors are selectively accessible. The sensor array reads complete serial data strings from the barcode track. At the same time a separate section of the array reads the very precise sine/cosine information, which is transformed into a high-resolution ARCTAN value within the hardwired ASIC. After synchronization of the two signals, the desired resolution and accuracy for the position data is obtained and transmitted over a two-wire

RS-485 channel. Absolutely no angular movement is required to read the position information.

The sine and cosine signals from the incremental track are output on separate analog channels, and can be used directly by the drive, or squared to provide a conventional A quad B digital signal. Thus, the SinCos® encoder can be used as an absolute, sine/cosine, or incremental feedback device.

## HIPERFACE® Interface

HIPERFACE® stands for High-Performance Interface, and describes a patented electrical interface between motor feedback devices and today's digital drive systems.

### Why HIPERFACE®?

With the increasing popularity of digital speed control devices, and the need for very precise low-speed control and positioning, there is a growing demand for high-performance motor feedback. Today's digital drives have cycle times in the microsecond range, and

## SinCos Encoder

## Digital Drive

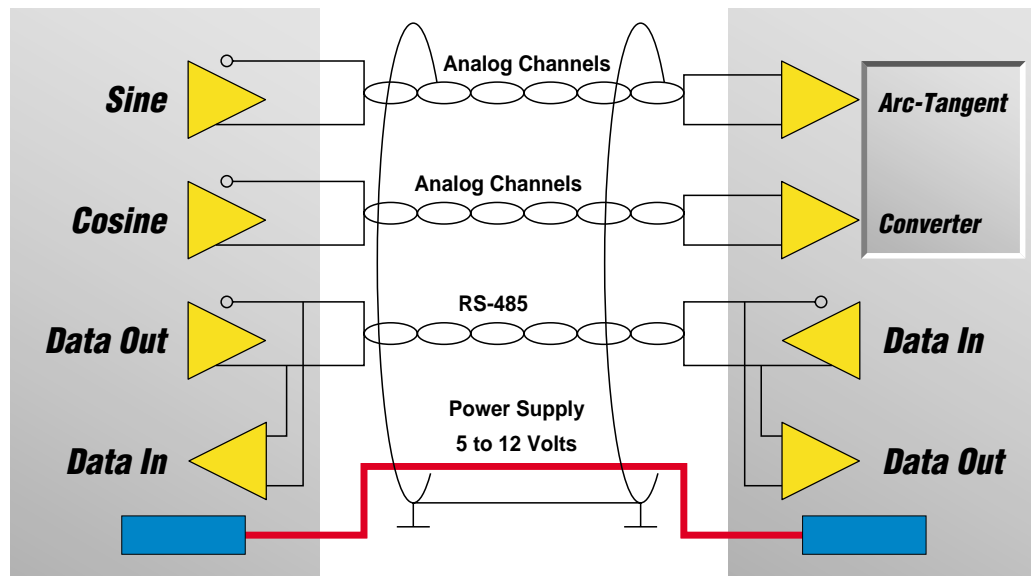

**HIPERFACE® uses a total of only eight wires for both absolute and Sine/Cosine feedback.**



For detailed, up-to-date specifications, CAD drawings, application examples and reference information, go to:

[www.stegmann.com](http://www.stegmann.com)

For documentation on specific products, use our fax back system in the web site or call our 24-hour fax back system

**916-431-6545**

and follow the recorded instructions. See the selection guides in this brochure for specific document numbers.

demand feedback devices with higher accuracy and resolution. Conventional feedback such as resolvers and incremental encoders no longer meet these increasing demands. Stegmann developed SinCos encoders, with the innovative HIPERFACE® interface, specifically to address these requirements.

#### How HIPERFACE® Works

The HIPERFACE® interface uses both the absolute and incremental data available from the SinCos® encoders to provide velocity, position and commutation information, along with smart sensor capabilities, to drives and controllers using a total of only 8 wires. The absolute position is typically read only when the device is initially turned on, and is transmitted to the drive via the RS-485 Interface. The drive uses this initial position for setting commutation of the motor, and as a starting point for the sine/cosine cycles that are available on the analog channels. The drive increases the base resolution of these sine/cosine signals by

subsequent interpolation in the drive.

Using analog signals for the incremental feedback offers the advantage of transmitting extremely high resolution at the lowest possible bandwidth. This approach gives the drive designer a high degree of flexibility concerning the drive's input circuit. For example, a servomotor operating at 6,000 rpm and a desired resolution of 20,000 pulses per revolution needs a bandwidth of 2 MHz, using conventional digital incremental feedback. If the SinCos is used, with 1024 sine/cosine cycles per turn, a bandwidth of only 102.4 kHz is required!

#### Additional Benefits of SinCos® Encoders with HIPERFACE®

- Sine/cosine signals have reference signals for maximum noise immunity.
- Temperature ratings up to 125°C. Encoder temperature monitored by integrated sensor.

- Only one electrical interface for the entire range of servo motor applications.
- An Electronic Nameplate (EE PROM) is available to store motor parameters (current, voltage, etc.) that can be used by the drive to initialize the system at start-up.
- Motor offset information can also be stored in the Electronic Nameplate, eliminating time-consuming mechanical alignment required for proper commutation.
- The Electronic Nameplate can also be accessed by the end-user, who can store information related to operating and maintenance history.
- A variety of shaft and mounting configurations is available to adapt to most motors with a minimum of design effort.
- SinCos® encoders are also available in stand-alone housings for use on non-motor axes, providing one common interface for all machine feedback requirements.

#### Single and Multi-Turn Absolute Encoders

Use single turn encoders when the full range of positions in the application occur within one full revolution (360°) of the encoder shaft. Multi-turn encoders are recommended for applications involving multiple revolutions of the encoder shaft.

In Stegmann multi-turn encoders, a high precision, miniaturized gear train, with a magnet on each gear stage, is used to mechanically store position information over as many as 4,096 turns. The position of each gear stage is determined with a pair of Hall sensors. This eliminates the need for costly and often unreliable counters and battery back up systems. Also, position changes that occur while the power is off are automatically tracked. ■



## Look At Who's Using HIPERFACE® ...



- A-Drive Technology
- ABB
- AMK
- Analog Devices
- Andrive
- Baldor
- Baumüller
- Bautz
- Beldrive Systems
- Berger Lahr
- Contraves Drives
- Control Techniques
- DDC
- Delta Tau
- DriveTech
- Elau
- Engel
- EPA
- EPH Elektronik
- ESR
- Eurolab
- Eurotherm Antriebe
- Fagor
- Ferrocontrol
- Georgii Kobold
- Groschopp
- Harmonic Drive
- Hauser Parker
- Haussmann
- HDD
- Infranor
- IRT
- Jetter
- KEB
- Kollmorgen Seidel
- Lenze
- Leroy Somer
- Lust
- Macon
- Mavilor
- Mayr
- Metronix
- Moog
- Motor Power Company
- MTS Automation
- NUM
- Octacom
- Oemer
- Oswald
- Pacific Scientific
- Quin
- Rockwell Automation
- Allen-Bradley
- Sanyo Denki
- S.B.C.
- Schneider Electric
- SCIWORX
- SEM
- Servax Drives
- SEW Eurodrive
- Sieb & Meyer
- SMB
- SSB
- Stöber
- Stromag
- System Antriebstechnik Dresden
- Wittenstein
- Ziehl-Abegg